

TREATMENT PLANT APPROVAL 04/2024
Plumbing and Drainage Regulation 2019, part 4



Approval

1. The **Ozzi Kleen GTS10** (“the System”) described in the Specifications and Drawings in the attached Schedule and manufactured by **Neatport Pty Ltd** (“the manufacturer”) (ABN 62 063 770 534) (“the manufacturer”) has been assessed in accordance with the *Queensland Plumbing and wastewater Code Version 1 2024 (QPWC)*.
2. Approval is granted for the system as an “**High-quality effluent**” wastewater treatment system, subject to compliance by the manufacturer with the requirements of the *QPWC - Schedule 1*, and the *Queensland Plumbing and Drainage Regulation 2019* and the conditions of approval detailed below.
3. As no changes have been made to the system, this approval replaces the previous Treatment Plant Approval (TPA) TPA 10/2021 Amendment 1 issued on 22 December 2023.
4. This approval, the conditions of approval and the Schedule comprise the entire Chief Executive Approval document.
5. Any modification by the manufacturer to the design, drawings or specifications scheduled to this approval must be approved by the Chief Executive.

Conditions of approval

6. The manufacture, installation, operation, service, and maintenance of the system must be in conformity with the conditions of this TPA.
7. The system may only be used on premises that generate per day:
 - (a) a maximum hydraulic loading of 2,000 L; and
 - (b) a maximum organic loading of 600 g BOD₅.
8. For the system to meet the requirements of an “**High-quality effluent**” greywater treatment system, the system must produce the following effluent quality —
 - (a) 90% of the samples taken must have a BOD₅ less than or equal 10 g/m³ with no sample greater than 20 g/m³; and
 - (b) 90% of the samples taken must have total suspended solids less than or equal 10 g/m³ with no sample greater than 30 g/m³; and
 - (c) 90% of the samples taken must have thermotolerant coliform count not exceeding 10 organisms per 100 mL with no sample exceeding 200 organisms per 100 mL.
 - (d) The total chlorine concentration shall be greater than or equal to 0.2 gm³ and less than 1.0 g/m³ in four out of five samples taken.
9. Each system must be serviced in accordance with the manufacturers details supplied in the owner’s service and maintenance manuals.
10. Each system must be supplied with —
 - (a) a copy of this Treatment Plant Approval document;
 - (b) details of the system and ancillary equipment;
 - (c) instructions for authorised persons for its installation;
 - (d) a copy of the owner’s manual to be given to the owner at the time of installation; and
 - (e) detailed instructions for authorised service personal for its operation and maintenance.

TREATMENT PLANT APPROVAL 04/2024
Plumbing and Drainage Regulation 2019, part 4.

11. This approval does not extend, apply to, or include the land application system used in conjunction with an approved system installed on premises.
12. At each anniversary of the Treatment Plant Approval date, the manufacturer must submit to the Chief Executive a list of all systems installed in Queensland that they have received an installation and commissioning certificate for during the previous 12 months.
13. Where the Chief Executive is notified of any system failures that they believe are a result of poor design or faulty manufacture, the Chief Executive may randomly select several installed systems for audit. The Chief Executive will notify the National Association of Testing Agencies (NATA) accredited laboratory nominated by the manufacturer, which systems are to be audited for Biochemical Oxygen Demand (BOD₅) and Total Suspended Solids (TSS). The sampling and testing of the selected systems, if required, is to be done at the manufacturer's expense. The following results must be reported to the Chief Executive;
 - (a) Address of premises.
 - (b) Date inspected and sampled.
 - (c) Sample identification number.
 - (d) Biochemical Oxygen Demand (BOD₅).
 - (e) Total Suspended Solids (TSS).
14. The Chief Executive may, by written notice, cancel this approval if the manufacturer fails —to comply with one or more of the conditions of approval; or within 30 days, to remedy a breach, for which a written notice been given by the Chief Executive.
15. This approval may only be assigned with the prior written consent of the Chief Executive.
16. This approval expires on **30 April 2029** unless cancelled earlier in accordance with paragraph 14 above.

Lindsay Walker



Director

Plumbing, Drainage and Special Projects

Date approved: 29 April 2024

Level 15,
53 Albert Street Brisbane
GPO Box 2457, Brisbane Qld 4001

Telephone +61 7 3008 2557

[Plumbing and drainage | Business Queensland](#)





TREATMENT PLANT APPROVAL 04/2024
Plumbing and Drainage Regulation 2019, part 4.

SCHEDULE

- Attachment 1 – Ozzi Kleen GTS10 Greywater Treatment System. – Owner’s manual
- Attachment 2 – Ozzi Kleen GTS10 Greywater Treatment System – Schematic diagrams.

TREATMENT PLANT APPROVAL 04/2024
Plumbing and Drainage Regulation 2019, part 4.

Attachment 1 – Ozzi Kleen GTS10 Greywater Treatment System. – Owner's manual

SUNCOAST WASTE WATER MANAGEMENT

Owners Manual
for
OZZI KLEEN
Greywater Treatment Plant
Model – GTS10



TREATMENT PLANT APPROVAL 04/2024
Plumbing and Drainage Regulation 2019, part 4.



CONGRATULATIONS

We would like to thank you for investing in an Ozzi Kleen package greywater treatment plant.

An Ozzi Kleen treatment plant consists of a single tank using a cyclic aerobic biological treatment process, designed to take all of your household greywater excluding the kitchen; i.e. bathrooms and laundry. The effluent is disinfected and may be reused for garden irrigation or for toilet flushing and laundry use.

Consider your Ozzi Kleen treatment plant as a small farm of micro-organisms consuming the waste that is discharged into it. Normal household greywater will be biologically treated to produce high quality treated water which may be reused.

Suncoast Waste Water Management specialise in domestic and commercial wastewater solutions.

Document No: P006
Revision: 6
Revision Date: 21/09/2010

Page 2 of 20

TREATMENT PLANT APPROVAL 04/2024

Plumbing and Drainage Regulation 2019, part 4.

TABLE OF CONTENTS

Interpretation	4
Statement	4
Models Available	4
Manufacturer’s Warranty.....	5
Installation Instructions	6
Plumber’s Installation Certificate	8
Electrical Requirements	9
How the Ozzi Kleen GTS Treatment Plant Works	10
Operating Instructions	12
Vacation of Premises.....	13
Treatment Plant Servicing.....	14
Troubleshooting Guide	15
Specifications	17
System Drawing.....	18
Safety Information	19

TREATMENT PLANT APPROVAL 04/2024

Plumbing and Drainage Regulation 2019, part 4.

INTERPRETATION

- (i) **‘Manufacturer’** includes Neatport Pty. Ltd. A.C.N. 063 770 534 trading as Suncoast Waste Water Management.
- (ii) **‘Purchaser/Owner’** shall mean the registered proprietor of the property where the Ozzi Kleen Greywater treatment plant has been installed.

STATEMENT

We, the manufacturer of the OZZI KLEEN greywater treatment systems, confirm that our treatment plants meet the requirements of the State Regulatory Authorities and has been accredited/certified by the following authorities:

Authority	Approval No.
Queensland Building Codes, Department of Local Government, Planning, Sport and Recreation	12/2006
SA Department of Health	WCS 2008
NSW Health Department	DGTS 003
Victoria EPA	CA102/05
Northern Territory Department of Health and Community Services	7/07/2007
SAI Global Standardsmark Licence	SMKH 20282

This equipment is covered under a manufacturer’s warranty as per the warranty conditions on page 5 of the Owner’s Manual.

This system has been designed to treat normal household greywater to the required standards as set by the State Regulatory Authorities. Greywater is defined as domestic wastewater excluding toilet waste and may include wastewater arising from a hand basin, bath, shower and laundry. **Sewage from toilets and wastewater from the kitchen must not be discharged to the greywater system.**

The greywater discharged to the system should not contain matter such as: plastics, paint, thinners, contents of a portable chemical toilet, or waste from garbage grinders, etc. The greywater should not contain excessive amounts of harsh cleaners, disinfectants, fabric softeners, fats, oils or grease.

This manual is for owners of the OZZI KLEEN system, which describes the proper function of the treatment plant, operating and maintenance responsibilities of the Owner and authorised personnel, and any service-related obligations of the Manufacturer.

MODELS AVAILABLE

Document No: P006
Revision: 6
Revision Date: 21/09/2010

Page 4 of 20

TREATMENT PLANT APPROVAL 04/2024

Plumbing and Drainage Regulation 2019, part 4.

GTS10 – Standard

- GTS10 - 1 * Upgrade to pressure pump (1 x float)
- GTS10 – 2 * Upgrade to pressure pump
 * Irrigation Control Solenoid (2 x floats)
- GTS10 – 3 * Upgrade to pressure pump
 * Irrigation Control Solenoid
 * Mains Water Diversion (3 x floats)

OPTIONS

- *U.V. Disinfection
- *MBR - Class A+ effluent quality

TREATMENT PLANT APPROVAL 04/2024

Plumbing and Drainage Regulation 2019, part 4.

OZZI KLEEN MANUFACTURER'S WARRANTY

Warranty is subject to the return of a signed **PLUMBER'S INSTALLATION CERTIFICATE**.
This Certificate is to be filled out and returned to the manufacturer as part of the Owner's Warranty Registration.

- Suncoast Waste Water Management warrants to the original purchaser that all equipment manufactured by Suncoast Waste Water Management is free from defect in material and construction at the time of despatch from the premises of Suncoast Waste Water Management.*
- This warranty is a return to base warranty which means the item must be returned to the manufacturer for repair. An exchange unit may be provided in this case. If replacement or service under this warranty policy is required and distance prevents you calling personally, forward your product freight prepaid to your nearest Service Provider.*
- This warranty does not extend to any claim made after a fixed period from the date of purchase for the following equipment:*

• Air Blower	24 months
• Effluent Pump	24 months
• Electrical components	12 months
• Electronic Control Box	24 months
• Main Tank	25 years
- All claims for warranty must be done through the retailer or supplier from whom the product was purchased. Proof of purchase must be supplied.*
- Any claim made in relation to this warranty is limited to the cost of replacement or repair of the equipment or such parts thereof claimed defective.*
- In the case of ancillary parts not manufactured by Suncoast Waste Water Management such as pumps, motors, starters, switches etc., the guarantee or warranty extended to the purchaser will be limited to the guarantee or warranty available from the manufacturer of that part.*
- This warranty is valid only when the equipment has been used in a normal manner and in accordance with the Owner's Manual and serviced by a duly authorised Ozzi Kleen Service Provider every 3 months.*
- This warranty does not cover any equipment that has been improperly installed, misused, neglected, damaged in transport, repaired without the authorisation of Suncoast Waste Water Management or altered in any way from its original condition at the date of purchase.*
- Adverse operating conditions beyond the control of Suncoast Waste Water Management such as lightning strikes, over voltage, under voltage, excessive ambient temperature, water damage, flooding, or any condition that adversely affects the performance or life of the equipment will render this warranty null and void.*
- Any costs incurred to repair a unit that is not covered by warranty will be passed on to the consumer including costs incurred to remove the faulty unit and replace with an exchange unit. Suncoast Waste Water Management is not responsible for any costs for goods not covered by this warranty.*
- Warranty work will not be performed until the customer has accepted the price quoted for the service call. Suncoast Waste Water Management will designate a minimum charge.*

Warranty does not cover:

- *Cleaning sprinklers of any blockages or damage to equipment caused by not clearing blockages.*
- *Any operational problems due to extraneous matter, excess fats or chemical spills in the greywater.*
- *Any parts broken or stolen from within the system due to transport or installation or misuse by any unauthorised persons.*
- *Any changes that are made to the treatment plant system from the original manufacture that is not approved by the manufacturer including components that maybe modified removed or replaced that alters the treatment processes.*
- *Service Provider's time for replacement of any faulty parts or cleaning out of treatment system.*
- *Service Provider's travel expenses (vehicle and travel time).*
- *Service callout costs.*
- *No warranty if the system has been used as an external power supply for other electrical appliances.*
- *No warranty if the seal on the control box has been broken.*

Document No: P006
Revision: 6
Revision Date: 21/09/2010

Page 6 of 20

TREATMENT PLANT APPROVAL 04/2024

Plumbing and Drainage Regulation 2019, part 4.

INSTALLATION INSTRUCTIONS

* Extract from Installation Manual - supplied with system, found in motor box.

PLUMBER'S INSTALLATION INSTRUCTIONS

- A hole for installation will have to be excavated approximately 2.5 m across and 2.4 m deep with a sound level base.
- A layer of bedding sand is required to make the finish level at 2.3 m deep (refer to drawing).
- If the hole is over excavated, extra bedding sand will be required.
- A normal installation of the treatment plant will locate the level of the inlet invert at 700 mm below natural ground level and 1600 mm above the sand base.

1. Install the treatment plant so that the tank is located central in the excavated hole with no less than 250 mm to the nearest side. Ensure that the backfill is placed evenly around the tank (see drawing).

If the system is placed unevenly in the hole so that the tank is near to touching a side of the hole this will not allow for even backfill and cause tank instability and will have to be rectified by the installer.

2. Install the treatment plant so that the base of the green motor box is no less than 50 mm above the natural ground level to avoid surface water entry.

If the system is installed too low it will have to be rectified by the installer.

3. The Ozzi Kleen treatment plant is to be completely filled with water (approximately 4,500 litres) or up to the sewer inlet before any backfill is placed around the tank. All compartments including sludge waste and effluent compartments must be filled.

Failure to do so will cause tank instability and any deflection to the tank will have to be rectified by the installer.

4. The system is to be installed in a position where local storm water flooding and ponding around the tank will not occur.

If the system is installed in a watercourse or a flood prone area the system will have to be relocated by the installer.

5. Landscaping or the importation of topsoil that is placed around the system after it is installed, which would cause the tank to be too low in the ground is to be avoided.

Imported topsoil that may be placed on the system after the installation will be the responsibility of the installer or owner.

6. When installing the system underneath a building ensures that there is sufficient head room for servicing.

A minimum of 1200 mm head room is needed for the service removal of some parts and retrieving of water samples at time of service.

Document No: P006
Revision: 6
Revision Date: 21/09/2010

Page 7 of 20

TREATMENT PLANT APPROVAL 04/2024

Plumbing and Drainage Regulation 2019, part 4.

IMPORTANT: TANK IS TO BE CENTRALLY LOCATED IN THE EXCAVATED HOLE WITH NO LESS THAN 250 mm CLEARANCE TO THE NEAREST POINT.

Top View

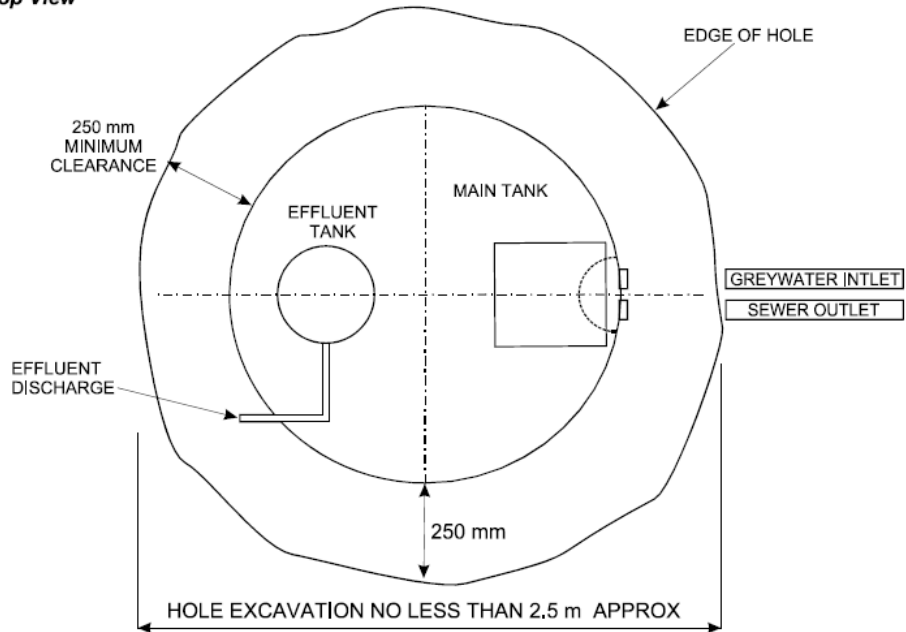

Side View

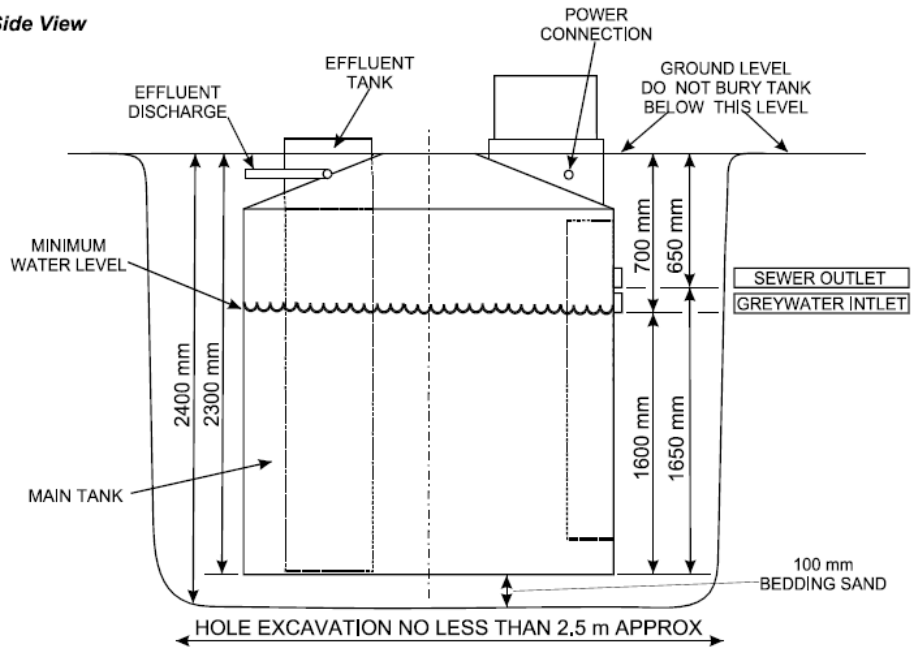

IMPORTANT:

Document No: P006
Revision: 6
Revision Date: 21/09/2010

Page 8 of 20



TREATMENT PLANT APPROVAL 04/2024
Plumbing and Drainage Regulation 2019, part 4.

- 1. FILL EFFLUENT TANK FIRST. (Approximately 500 litres)**
- 2.FOLLOWED BY MAIN TANK WITH WATER, (APPROXIMATELY 4,000 LITRES) PRIOR TO BACKFILLING.**

Document No: P006
Revision: 6
Revision Date: 21/09/2010

Page 9 of 20

TREATMENT PLANT APPROVAL 04/2024
Plumbing and Drainage Regulation 2019, part 4.

PLUMBER'S INSTALLATION CERTIFICATE

The Ozzi Kleen System must be installed as per the following instructions. This form is to be filled out and returned to the manufacturer or their agent as part of the Owner's warranty registration.

PLEASE TICK ALL THE BOXES DURING THE INSTALLATION

1. Excavate hole - 2.5 m diameter and approximately 2.4 m deep
2. Place a layer of bedding sand in the hole
3. Check depth from sand bed to natural ground level no greater than 2300 mm
4. Check depth from inlet invert to bedding sand no greater than 1600 mm
5. Check depth of inlet invert to natural ground level no greater than 700 mm
6. Check that motor box hinges are at least 50 mm above the natural ground level
7. Fill effluent tank, followed by main tank to sewer inlet with water (approximately 4,500 litres)
8. Connect sewer piping to the sewer inlet
9. Backfill around tank with clean earth only, (free from large lumps of clay, stones, bricks, foreign objects, or dumped rubbish from other trades persons)
10. The irrigation system could be of several different formats, check for Council requirements

INSTALLATION CERTIFICATION

The Ozzi Kleen system has been installed according to the above procedures by an approved installer.

OZZI KLEEN SERIAL No: _____

NAME OF INSTALLER: _____

INSTALLER'S LICENCE No: _____

INSTALLER'S SIGNATURE: _____

DATE OF INSTALLATION: _____

LOCATION OF INSTALLATION: _____

TREATMENT PLANT APPROVAL 04/2024

Plumbing and Drainage Regulation 2019, part 4.

ELECTRICIAN'S INSTRUCTIONS

INSTALLATION OF POWER TO THIS UNIT MUST BE PERFORMED BY A LICENCED ELECTRICAL CONTRACTOR IN ACCORDANCE WITH THE CURRENT ELECTRICITY ACT.

- The power supply to the Treatment Plant is a single-phase service and should be wired in 2.5 mm² cable.
- The alarm circuit is supplied from the control board and is 24 V DC. As the alarm cables are run with the supply cables to the plant, they must be rated for 240 V but may be 1 mm² cable.
- The maximum power consumption of the Treatment Plant is approximately 800 Watts.
- The air compressor is rated at 100 Watts.
- The effluent pump is rated at up to 750 Watts. – (1000 W. with pressure pump)
- The power supply to the system should come direct from the meter board and be protected by a 10 A RCD (Residual Current Device) and surge protection. The main power point may be considered for general use, therefore it must be RCD protected. It is recommended that the system be connected to an individual dedicated electrical circuit.
- The alarm mute switch and alarm lights are on a common switch plate, which is to be mounted in the Owner's house at an appropriate point. (The switch plate is found in the green motor box).
- There are 3 alarms available, all of which are activated via the 4 core alarm cable. The alarm connections are not polarity sensitive and must be connected correctly
- Cabling between the dwelling and Treatment Plant should be installed using adequate protection/conduit. 2 cables will be required - 3 core for power supply and 4 core for alarm circuit.
- The Alarm Connections

Alarm Wire Colours	Alarm Plate Connections
• Red	• Terminal Strip on Alarm Panel
• Yellow	• Common on Mute Switch
• Blue	• Loop on Mute Switch
• Green	• 1 on Mute Switch

The power supply cable is brought into the Treatment Plant through the side of the tank turret at the top of the tank, referred to as the access manhole, and up through the floor of the motor box housed in the flexible conduit provided. The 240 V supply is to be connected to the main power outlet inside the motor box. The low voltage alarm wires are to be connected to the terminals inside the small round junction box below the main power outlet. The external electrical conduit to the system is to be 25 mm.

Note:

The motor compartment on the top of the Treatment Plant is on a hinged lid and the wiring to this compartment passes through a flexible conduit provided. No external conduit or rigid conduit is to be fastened to the outside of the motor box. If extra flexible conduit is used for wire connection to the system, ensure that there is sufficient length to allow for the tilting of the motor box when it is opened. The power supply cable is to be connected to weatherproof outlet provided and alarm cable to be connected to terminal strip inside of PVC junction box provided. No other connections are required.

HOW THE OZZI KLEEN GTS TREATMENT PLANT WORKS

Document No: P006
Revision: 6
Revision Date: 21/09/2010

Page 11 of 20

TREATMENT PLANT APPROVAL 04/2024

Plumbing and Drainage Regulation 2019, part 4.

OZZI KLEEN ‘GTS’ (greywater treatment system) works with a cycled aeration process built into a single tank designed to accept and treat all the household greywater excluding kitchen wastewater; i.e. greywater from bathrooms and laundry. The waste products in the greywater are completely consumed by naturally occurring bacteria in the oxygen-rich environment in the aeration tank. The system treats the organic waste to produce treated water of a high standard.

The treatment plant consists of a round polyethylene tank with an internal effluent compartment and pumping system. The tank is robust and suitable for in-ground burial or for free standing above-ground installations, depending on the layout.

Where the treatment plant is installed in the ground, the house drain may be connected direct to the inlet on the side of the main tank. In the event of the system being installed in a city sewered area the treatment plant has an overflow which discharges directly from the main aeration tank to the sewer. The system would only overflow if the treated effluent was not being pumped away fast enough for some unexpected reason.

Where the treatment plant is installed above ground, a domestic greywater pump station would need to be provided to lift the greywater into the treatment plant. The pump station should be fitted with an overflow discharging to the sewer similar to that above.

If approved for connection to the household facilities:

A town water top up system can be fitted if approved by the relevant authority and would only add water to the system if the demand in the home exceeded the greywater contribution. Refer to the GTS System Drawing.

Effluent Pump and Controls

The effluent storage compartment holds approximately 500 litres of water which gives sufficient storage for normal household use, 300 litres of which is for inhouse use, which is considered to be sufficient to service the house hold facilities (toilets and laundry) in the event of fluctuating flows of grey water discharged to the system to be treated.

The effluent storage compartment has a submersible pump controlled by a pressure switch and float switches. When there is a water demand from the services within the house, the pressure switch senses the pressure drop and switches on the pump.

There are three float switches within the effluent storage compartment, set at different levels to control the effluent pump and mains make-up water supply as follows: Refer to the GTS System Drawing.

1. Float switch “A” operates solenoid valve “A” to control effluent discharge to the irrigation area only. This provides for disposal of excess effluent when there is a low demand from the services within the household.
2. Float switch “B” operates solenoid valve “B” to control the town mains make-up water supply to the effluent storage compartment. Mains water will only be required when the demand from the services within the household exceeds the flow of treated greywater coming from within the system.

Float switch “C” controls the pump to prevent the pump from running dry, should there be no water flowing from either the greywater treatment system, or the mains supply.

TREATMENT PLANT APPROVAL 04/2024

Plumbing and Drainage Regulation 2019, part 4.

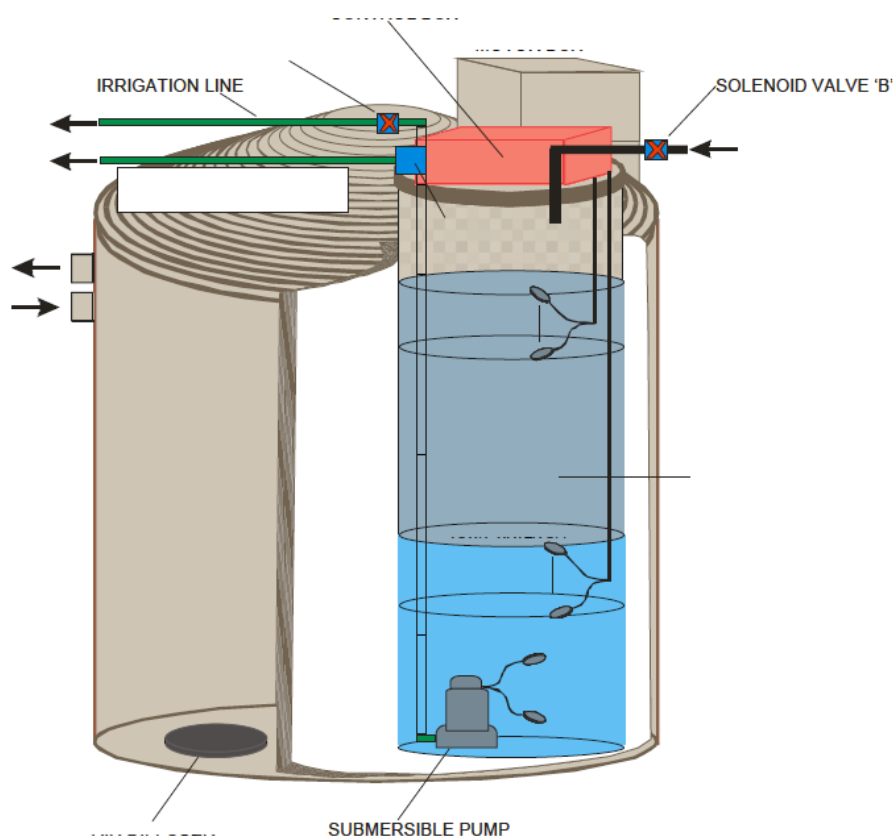

The Treatment Cycle

Aeration Cycle

The incoming greywater is aerated and oxygenated with air supplied by the air blower. As aeration takes place, an aerobic environment is provided for micro-organisms. These organisms grow and establish an “activated sludge”. The activated sludge will oxidise the organic waste as long as a balance between the air feed and the organic/hydraulic load is maintained.

Settling Cycle

After the aeration cycle, aeration ceases for approximately 60 minutes, allowing the activated sludge to settle to the bottom of the aeration tank. A layer of clear water is then formed at the top of the aeration tank.

Decanting Cycle

After a predetermined settling period, a decanting operation takes place. The decanter device draws off effluent from the top of the aeration tank. The decanting cycle continues until either the liquid level in the tank reaches the minimum level, or the process timer puts the system back into the aeration cycle, which in turn stops the decanting cycle.

While decanting, the effluent is chlorinated and stored in the effluent storage compartment to ensure disinfection of pathogenic organisms prior to discharge. The effluent pump will pump out the disinfected effluent to the household for reuse.

OPERATING INSTRUCTIONS

Document No: P006
Revision: 6
Revision Date: 21/09/2010

Page 13 of 20

TREATMENT PLANT APPROVAL 04/2024

Plumbing and Drainage Regulation 2019, part 4.

The treatment plant has to be commissioned to ensure that the system is set up correctly and is operating and ready for use. The system *must not be used* until it is fully commissioned. The Service Provider will carry out commissioning.

The Ozzi Kleen treatment plant should operate normally and may require a few simple regular checks that should be performed.

- Check that the irrigation system is working properly (if sprinklers are fitted). Check and clean regularly, making sure they are operating. This may be a weekly occurrence.
- The chlorine tablets supplied should be sufficient for the period between services. Normally two kilograms of chlorine is placed in the system at each service. If the tablets have been consumed before the next service, more chlorine tablets will have to be added. Contact the Service Provider for replacement tablets, or obtain your own from a local supermarket or pool shop (Trichlor jumbo pool chlorine tablets).
- Keep the area around the treatment plant in a clean state, to avoid any damage to the treatment plant from fires, vehicular traffic etc.
- The ground level around the irrigation outlet pipe may subside, causing a load on the pipe. Please ensure that the pipe is not pulled out of the tank by soil movement.

DON'TS: For your own convenience there are a number of **DON'TS** that you should be made aware of:

Do not discharge any items to the treatment plant that cannot be biologically broken down or are not a source of food for the micro-organisms i.e:

- Plastics, paint, thinners, contents of a portable chemical toilet, or any other foreign matter.
- Large quantities of harsh cleaners, disinfectants, fabric softeners, or any other substances or poisons that would be harmful to your system's ecology. Preferably use bio-degradable products as this will also help the environment).

As the owner of your treatment plant, it is to your advantage to understand the operating principles of the system and be observant as to what is happening from day to day. Look after your treatment plant and it will serve you well.

NOTE:

- *If the Treatment Plant biomass has been killed-off, the power disconnected, or any of the above "Don 'ts" put into the system, you may need to engage your Service Provider to rectify the problem.*
- *The Treatment Plant is never to be emptied without prior consent by the Manufacturer / Service Provider.*
- *Always unplug the Air Blower before tilting motor box to avoid internal damage.*
- *The Mains power supply is to be left on at all times.*

In the event of power failure, no water will be pumped from the system. During a power failure, the main aeration tank may fill to the high level. If more greywater is discharged to the system, then the excess greywater will overflow to the sewer. The overflow of the system will not affect the treated water in the effluent holding compartment.

TREATMENT PLANT APPROVAL 04/2024

Plumbing and Drainage Regulation 2019, part 4.

In the event of operational problems you should contact your Service Provider who will ensure that the situation is corrected after determining the fault or cause.

Foaming: Foaming may occur with a new system due to laundry suds. The system operates initially with aeration of clean water, so with the addition of soaps it can sometimes cause a foaming effect. The system requires bio-solids and this will take effect in a few days after normal household use and will overcome foaming.

This may be avoided by reducing excessive washing activity on a newly commissioned system.

If you are at any time renting out your property, please advise the tenants of the operating procedures.

VACATION OF PREMISES

If you are vacating your premises for a period greater than 6 months, please contact your local authorised Ozzi Kleen Service Provider. Your Service Provider will be able to advise you of the appropriate measures to take on vacating your premises.

On your return, contact your authorised Ozzi Kleen Service Provider for recommissioning of the system.

TREATMENT PLANT SERVICING

The Ozzi Kleen system is to be serviced every 3 months, in accordance with State and Territory regulatory authorities. A test report is to be completed by an authorised Ozzi Kleen Service Provider on each service, and supplied to the Purchaser/Owner and Local Authority. This report outlines water quality tests performed, plant operation and condition of the irrigation area.

The Purchaser/Owner may enter into a twelve month maintenance agreement for the servicing of the Ozzi Kleen Greywater treatment plant.

All servicing should be carried out by the authorised Ozzi Kleen Service Provider or by any person or persons duly authorised in writing by the Manufacturer.

The Purchaser/Owner shall provide reasonable access to the treatment plant as necessary to carry out the regular servicing as described in this clause.

Chlorine tablets are replenished with each service.

The amount of chlorine replaced is dependant on the consumption, so that at the time of each service the chlorinator will be topped up so that there will be at least four kilograms of tablets left in the system.

If the chlorine usage is higher, there is provision to hold up to four kilograms in the system.

PLEASE NOTE: In the event of any service queries, please refer directly to your local authorised Ozzi Kleen Service Provider.

TREATMENT PLANT APPROVAL 04/2024

Plumbing and Drainage Regulation 2019, part 4.

TROUBLESHOOTING GUIDE

The treatment plant has an audio-visual in-house alarm panel mounted inside your home. The alarm has a mute switch which can be turned off until the problem is rectified. If the alarm situation is not addressed within 8 hours, the alarm will reactivate.

In the event of any troubleshooting query, please refer directly to your local authorised Ozzi Kleen Service Provider.

OPERATION PROBLEM	CAUSE	REMEDY
1. Pump Alarm	a) Effluent pump runs but does not lower water level. i) Blocked sprinklers. ii) Irrigation line kinked. iii) Pump suction clogged with rags.	a) Pump checks: i) Check sprinklers. Clear any blockages. ii) Check irrigation line for kinks. iii) Call Service Provider.
2. Blower Alarm	a) Broken or damaged air lines causing low air pressure. b) Air diffusers ruptured. c) Faulty blower components. d) Blower protection switch activated (Yasunaga Blower only).	a) Call Service Provider. b) Call Service Provider. c) Call Service Provider. d) Call Service Provider.
3. Treatment Plant Smelling	a) Power turned off due to alarm being activated. b) Plant biomass killed-off. The biomass may be killed-off by toxic chemicals discharged to the system; i.e. harsh cleaners, portable chemical toilet contents, excessive antibiotics, etc. c) Diffusers blocked causing loss of aeration. d) Diffuser partly ruptured causing poor aeration. e) Plant put into use prior to commissioning.	a) Always leave power on. b) Pump out aeration tank and refill with clean water. c) Call Service Provider. d) Call Service Provider. e) Do not use treatment plant before commissioning. Septic, anaerobic conditions in the treatment plant will cause odours.

TREATMENT PLANT APPROVAL 04/2024

Plumbing and Drainage Regulation 2019, part 4.

SPECIFICATIONS

Parameter	Raw Greywater Characteristics	
Greywater treatment capacity	10 persons EP at 200 l/person/day	
Maximum hydraulic load	2,000 l/day	
Biological Oxygen Demand (BOD ₅)	300 mg/litre or 60 g/day/person	
Total Suspended Solids (TSS)	300 mg/litre or 60 g/day/person	
Total grease and oils	75 mg/litre	
Greywater temperature range	10°C to 38°C	
Parameter	Effluent Standard: Guaranteed (90 th percentile)	Effluent Standard: Test Results (90 th percentile)
BOD ₅	< 10 mg/l	< 4 mg/l
Suspended Solids	< 10 mg/l	< 8 mg/l
Total Nitrogen	< 20 mg/l	< 16.7 mg/l
Total Phosphorous	< 10 mg/l	< 7.29 mg/l
Thermotolerant Coliforms	< 10 colonies per 100 ml	0 colonies per 100 ml
Free Chlorine	> 0.5 -- < 4.0 mg/l	< 4.0 mg/l
Effluent is suitable for toilet flushing / washing machine reuse		

Treatment Plant Construction:

Tank and components Polyethylene (MDPE)
All Pipe work PVC

Electrical Equipment:

Air Blower 85 litre/min
Effluent Pump Submersible
Controls Electronic

Alarm System:

Alarm System 12 Volt Audio/Visual
Alarm signal Indicator lights for Power, Blower

Aeration Tank:

Aeration tank volume 4850 litre
Residence time 46 hr

Disinfection equipment:

Chlorinator Type Tablet Dispenser Cassette
Chlorine min contact time (max flow) 86 min

Motor Box:

Equipment Contained Air Blower, Control Board,
Decanter Solenoid Valve equipment

Effluent Tank and Pump:

Effluent storage compartment volume 523 litres
Effluent pump duty 40 litres/min @ 8 m head
Pump Mounting Suspended on discharge pipe

Irrigation Equipment: Basic irrigation equipment is supplied with the treatment plant. The irrigation system could be of several different formats. Check with Local Authority requirements.

TREATMENT PLANT APPROVAL 04/2024

Plumbing and Drainage Regulation 2019, part 4.

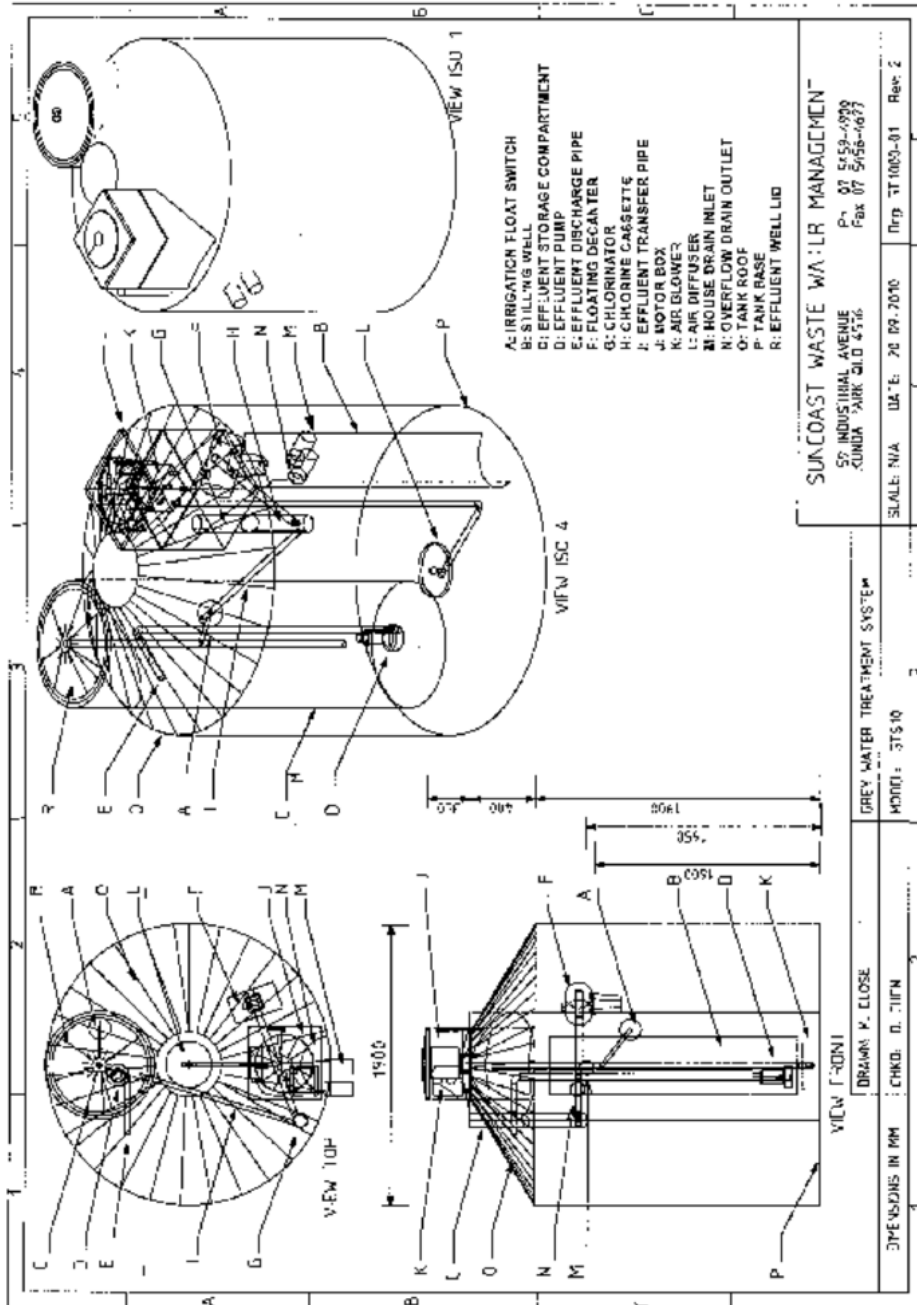

Document No: P006
 Revision: 6
 Revision Date: 21/09/2010

TREATMENT PLANT APPROVAL 04/2024

Plumbing and Drainage Regulation 2019, part 4.



SAFETY INFORMATION

Never enter any compartment of the treatment plant.

There could be potential hazards from:

- Drowning in the tanks,
- Asphyxiation from an oxygen depleted atmosphere within the tanks.

There are four accessible compartments:

- The motor box control compartment, which is accessible through the top lid.
- The main aeration tank, which is accessible by tilting the motor box on its hinges.
- The effluent tank with its pump, which is accessible through one of the large round lids.
- The chlorinator, which is accessible through the small round lid between the motor box and effluent tank.

All access lids are normally secured with set screws. The Owner should ensure that they are all in place after any inspection has been carried out.

Signs indicating that the treated water is recycled and is **not fit for drinking** have been provided and are to be erected in the irrigation area. This is a State Regulatory Authority requirement in all areas.

The OZZI KLEEN system operates on a 240 V power supply.

The main power outlets within the motor box are intended for the use of the treatment plant equipment only. These should be kept plugged in at all times. The power outlets cannot be used for any other power appliances. Plugging anything else into these outlets will affect the systems controls.



TREATMENT PLANT APPROVAL 04/2024
Plumbing and Drainage Regulation 2019, part 4.

Please contact your Ozzi Kleen Service Provider with any queries:



Manufactured by: Suncoast Waste Water Management
59 Industrial Avenue, Kunda Park, QLD, 4556
Ph: 07 5459-4900
Fax: 07 5456-4677
Email: info@ozzikleen.com
www.ozzikleen.com

Document No: P006
Revision: 6
Revision Date: 21/09/2010

Page 20 of 20

Attachment 2 – Ozzi Kleen Greywater Treatment System - Schematic diagrams.

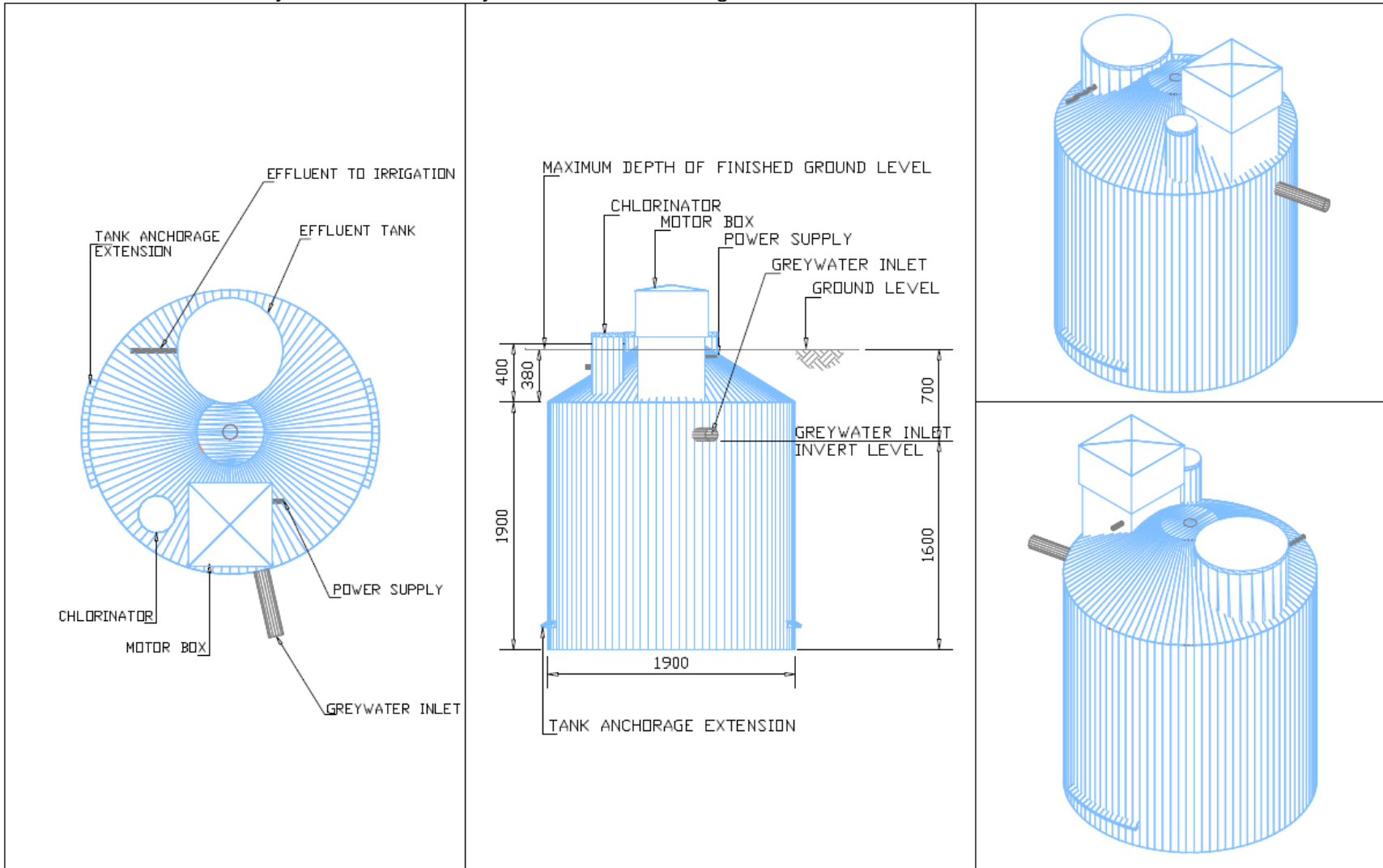

DATE	DESCRIPTION	REV.	BY
17/06/11	GENERAL REVISION	1	DC



Suncoast Waste Water Management

58 INDUSTRIAL AVE
KUNDA PARK
QLD 4556
PH +61 7 5459 4900
FAX +61 7 5456 4677
www.ozzikleen.com

CLIENT	GENERAL	DESIGN	DC
DRAWN		DRAWN	DC
PROJECT	GREYWATER TREATMENT SYSTEM	CHKD	MC
TITLE	GTS10 – SYSTEM DETAILS	DATE	17/06/11
DWG NO.	GD-GTS10-H10.A	SCALE	NTS

